

VOLVO CONSTRUCTION EQUIPMENT

C-SERIES SKID STEER LOADERS

ROC : 610-1 180 kg 36-55 kW



A PASSION FOR PERFORMANCE.

At Volvo Construction Equipment, we're not just coming along for the ride. Developing products and services that raise productivity – we are confident we can lower costs and increase profits for industry experts. Part of the Volvo Group, we are passionate about innovative solutions to help you work smarter – not harder.

Helping you to do more

Doing more with less is a trademark of Volvo Construction Equipment. High productivity has long been married to low energy consumption, ease of use and durability. When it comes to lowering life-cycle costs, Volvo is in a class of its own.

Designed to fit your needs

There is a lot riding on creating solutions that are suited to the particular needs of different industry applications. Innovation often involves high technology – but it doesn't always have to. Some of our best ideas have been simple, based on a clear and deep understanding of our customers' working lives.



You learn a lot in 180 years

Over the years, Volvo has advanced solutions that have revolutionized the use of construction equipment. No other name speaks Safety louder than Volvo. Protecting operators, those around them and minimizing our environmental impact are traditional values that continue to shape our product design philosophy.

We're on your side

We back the Volvo brand with the best people. Volvo is truly a global enterprise, one that is on standby to support customers quickly and efficiently – wherever they are.

We have a passion for performance.



Volvo Trucks

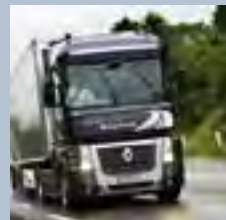

Renault Trucks



Mack Trucks



UD Trucks

Volvo Buses

Volvo Construction Equipment

Volvo Penta

Volvo Aero

Volvo Financial Services

WORK COMFORTABLY.

It's proven that less fatigue means more productivity. The Volvo cab has it all. It features comfortable operation, both at the controls and in regard to its low noise level. It also has plenty of personal space to make operators feel more at ease.

Comfort cab

The new skid steer loader cab is spacious and safe. It meets the ROPS/FOPS safety standards and offers operators 27% more space over previous models. Increased comfort means extended operator productivity.

Ample storage

Storage space is conveniently located under the left hand armrest. This easily accessible area gives the operator a secure place to store personal items such as keys. There is also a 12V power outlet here.



Interior noise

All models – both canopy and enclosed cab – are designed to limit noise in and around the operator environment. Less noise reduces operator fatigue and creates a more comfortable working environment.

Instrument consoles

Two consoles, positioned in the upper front cab corners, provide easy to read gauges. Simply presented instruments, situated for operator comfort, ensure easy viewing.



Cab access

Large side door allows operators to safely enter and exit the machine without climbing over an attachment. This minimizes the risk of slipping and the need to turn to sit down. Operators access the cab via a non-slip step. In a raised loader arm service position operators do not need to walk under the loader arm to engage the support strut.

DESIGNED FOR PERFORMANCE.

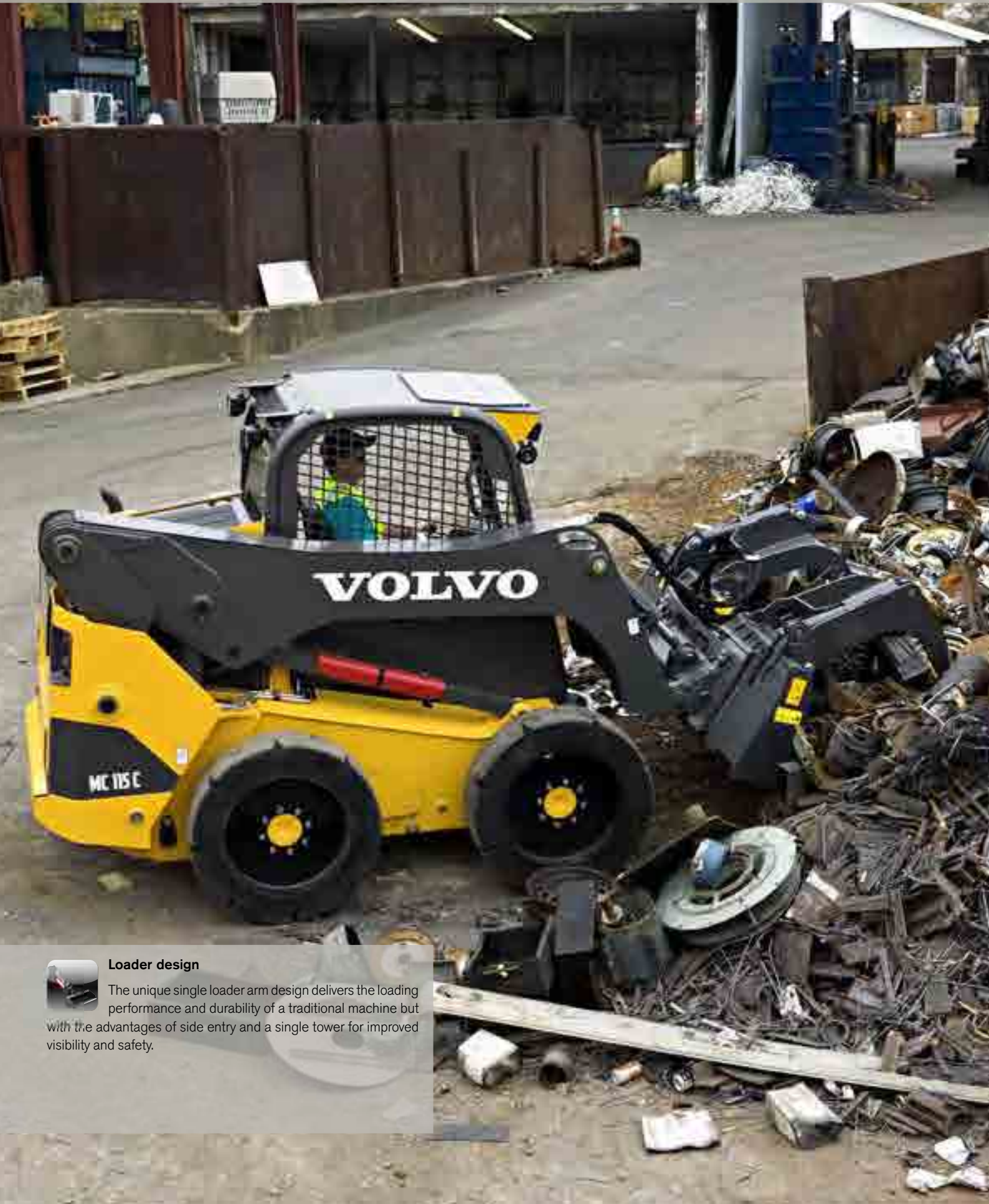

Loader design

The unique single loader arm design delivers the loading performance and durability of a traditional machine but with the advantages of side entry and a single tower for improved visibility and safety.

Our unique, single loader arm design affords operators many performance advantages. It's durable, it's safe and it provides excellent visibility. With high capacity and built in efficiency, you can perform at a higher level.

Weight distribution

Weight is evenly distributed across the machine providing stability when handling both heavy and light loads. The offset cab and engine compartment counterbalance the unique single loader arm ensuring ultimate stability and balance from side to side.



Vertical lift

Excellent vertical lift that is perfect for truck loading and material handling applications due to the increase in height and reach. Also delivers greater lift capacity for efficiency in repeated load and carry operations.

Greater fuel capacity

Best-in-class fuel tank capacity means longer operating shifts and more productivity. Spend less downtime refueling.

EASIER SERVICE. LONGER LIFE.

Access greater uptime with user-friendly serviceability. Perform routine daily checks or access major components - it's all within easy access. This means you spend less time maintaining your machine and more time earning money.

O-ring face seals

Hydraulic connections use o-ring face seal (ORFS) fittings to eliminate hydraulic leaks. ORFS connectors reduce downtime and service costs by providing a 100% leak free joint.



Loader pivot pins

Our loader arm pivot pins are larger and therefore stronger than those used by competitors. They effectively distribute the load over the single arm design for longevity and durability.



Cab tilt

The entire cab can easily be tilted forward by one person with the removal of two bolts from the inside. Gas struts lock into place for simple, safe and quick access to key internal components.



Service access

Easy service access due to single loader arm, forward-tilting cab and large rear and top door. The skid steer loaders have 24% better SAE serviceability than competitor machines. Simple access to service and maintenance items helps provide a longer operating life.

SEE IT ALL. DO IT ALL.



Visibility

The single tower loader arm – with no horizontal cross member on the vertical lift model – provides superior visibility. The machine has a large top window and narrow ROPS cab pillars. The unique features help the operator maneuver the machine in tight areas to maximize productivity.

You know the work is out there. And when you can see it all clearly, you get more of it done. Experience leading visibility all around the jobsite. Work in safety. Work with peace of mind. Work with your Volvo skid steer loader.

Cab door

The side door is the entire length of the cab. An unobstructed view provides improved visibility without the challenges found in other side mesh cages used in competitor machines. The door opens wide to 75 degrees ensuring easy entry and exit.



Loader arm service position

The side entry and exit cab makes engaging the loader arm support a one man operation. The operator can safely exit the machine to the side and walk round the rear without passing under the loader arm.



Safety first

The large front window provides an emergency exit 2.5 times bigger than the rear emergency exit in traditional front entry machines. ROPS/FOPS and easy machine exit gives operators peace of mind in the unlikely event of machine roll-over or falling objects.

TAKE A SPIN AROUND.

Vertical lift

Ideal lift, height and reach for truck loading and material handling applications.



Loader design

Single loader arm design for performance, durability, improved visibility and enhanced side-entry cab access.

Radial lift

Ideal loader path for heavy duty attachments and ground engaging applications.



Customer support

Volvo will support your skid steer loader with all the parts and service assistance you need.

Attachments

The versatility and power to use a wide range of attachments in a multitude of applications.





Cab

Designed for space, safety and comfort with ROPS/FOPS and large emergency exit.

Versatility

Increased flexibility to handle more jobs with just one machine.



Cab access

Safer side entry access eliminates the need to climb over a muddy and slippery bucket or attachment.



Visibility

Single tower loader arm and large top window for all-around, class-leading visibility.



Service access

Simple, safe access to all service and maintenance areas with a forward-tilting cab and a large rear compartment door.



ATTACH AND GO.

Unleash your machine's true potential with our extensive range of attachments. Our attachments work hard for you increasing your productivity and profitability across segments including building, landscaping, demolition and road construction.

A sample of some of the attachments offered

Auger

Powerful, smooth and easy for fast, effective ground hole drilling. Accepts multiple auger bits for application versatility. Hydraulically powered. Protected couplings for dependability, long life and lower costs.

Pallet forks

For pallet and material handling. Heavy-duty design provides fork strength to handle all the loads. Maximum open space between frame structure. Ideal visibility for fast, safe material handling.



6 in 1 bucket

Provides versatile material handling to dig, load, dump, push, grapple and level. Adds machine flexibility for a wide range of applications. Provides good visibility to the attachment edge.

Trencher

Ideal for utility trenching and pipe laying. High torque hydraulic motor. Heavy-duty design for dependability and long life. Provides maximum digging power for faster work. Greater versatility for increased profit opportunity.

Dozer blade

Heavy-duty, dozer blade effectively pushes and removed material. Replaceable wear parts prolong life. Optimum pushing power for fast work in heavy conditions. Year-round versatility, for use in snow and loose dirt.



Hydraulic breaker

Break through hard materials quickly and easily! Delivering consistent impact energy and superior performance, diaphragm breakers require much less maintenance.



Scrap grapple

The easy way to handle bulky or loose material of varying sizes, not just in scrap applications. High-capacity handling with outstanding material retention. Provides excellent ground visibility for safe handling. Strength and durability for long life.

Broom

A wide range of brooms are available for versatility to suit multiple applications. Ideal for fast and effective site cleanup, public maintenance, debris pickup and more. Provides an optimal view for safe, quick work.

BUILT TO RUN. SUPPORTED FOR LIFE.

Volvo will support your skid steer loader with all the parts and service assistance you need. We have a strong team of local dealers on hand to assist you to make sure your machines perform at their best and have a long operating life. Volvo won't let you down.

Dealer support network

Whatever you do, wherever you go, your Volvo Construction Equipment dealer is there with you – around the globe. A comprehensive range of dependable Volvo equipment. Trusted industry experience. Reliable parts and service support. Your local Volvo dealer is in the right place to find the right solution.

State-of-the-art machines require state-of-the-art support and your Volvo dealer can provide a catalogue of services designed to get the most out of your machine, helping you maximise uptime, productivity and resale

value. Your local Volvo dealer can provide a number of sophisticated support offers, including:

Service plans ranging from routine wear inspections, through to comprehensive maintenance and repair agreements.

Analysis and diagnostics to help you understand how your machine is running, highlight potential maintenance issues and identify where performance can be improved.



Service and support

Your dealer is ready to help increase your uptime by attending to your service needs and offering expert support. With trusted industry experience and solutions for all your jobs, Volvo offers first class support.



Taking care of your needs

Rely on your local Volvo dealer for all the support services you need. They've got the tools to help you achieve more and increase profits.

VOLVO C-SERIES SKID STEER LOADERS IN DETAIL.



	Units	MC60C	MC70C
Engine			
Model		404D-22	404D-22T
Cylinders		4	4
Fuel type		Diesel	Diesel
Displacement	cm ³	2 200	2 200
Aspiration		Naturally aspirated	Turbo
Cooling system		Liquid	Liquid
Horsepower			
SAE gross power	kW / hp	35.7 / 47.9	44.7 / 59.9
SAE net power	kW / hp	35.1 / 47.1	43.9 / 58.9
@ engine speed	@ rpm	2 800	2 800
Max. gross torque	Nm	143	189
@ engine speed	@ rpm	1 200	1 200
Electrical system			
Battery	V - Ah	12 - 109	12 - 101
Alternator	Ah	65	85
Starter	kW	2	2
Drivetrain			
Tires		10x16.5 - 8 PR	10x16.5 - 8 PR Wide
Hydraulics system-loader			
Std hydraulic pump output flow	lpm	70	70
High flow pump output	lpm	-	100
Engine speed	@ rpm	2 800	2 800
System pressure	bar	230	230
Service capacities			
Cooling system	l	15	15
Engine crankcase with filter, change	l	10.6	10.6
Fuel tank	l	98	98
Hydraulic system - total capacity	l	43.5	43.5
Hydraulic reservoir capacity	l	26	26
Performance			
Lift arm path		Radial	Radial
Rated operating capacity (SAE)	kg	612	703
Tipping capacity (SAE)	kg	1 356	1 406
Operating weight (SAE)	kg	2 752	2 844
Breakout force, lift	kg	1 440	1 770
Breakout force, curl	kg	1 820	1 820
Maximum travel speed			
Single speed	km/h	12	12
Two speed	km/h	-	9 / 18.5
Cycle time			
Raise (lifting)	s	2.8	3.2
Lower (power down)	s	1.4	1.8
Curl	s	1.4	1.4
Dump	s	1.8	1.8

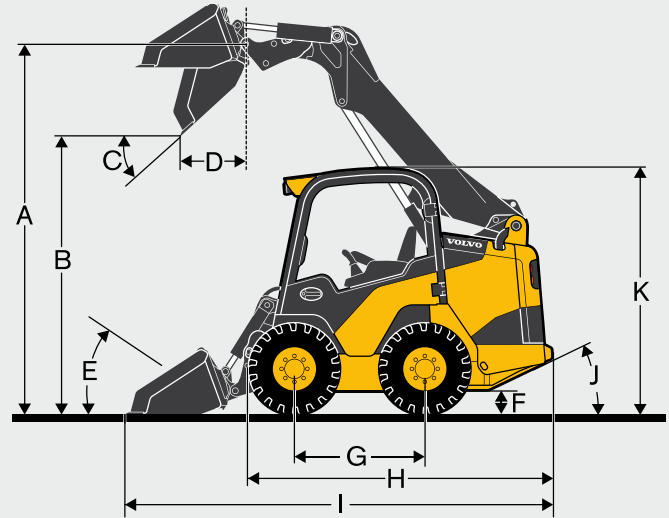
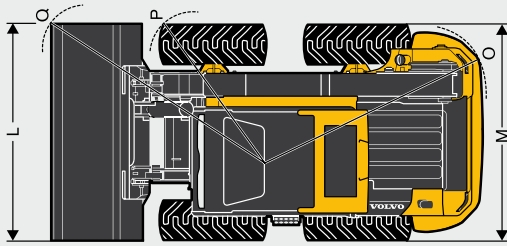

	Units	MC60C	MC70C	
A	Height to hinge pin	mm	3 000	3 000
B	Dump height	mm	2 260	2 260
C	Dump angle	°	42	42
D	Dump reach	mm	560	560
E	Roll back angle	°	30	30
F	Ground clearance	mm	210	210
G	Wheelbase	mm	1 070	1 070
H	Overall length (L/bucket)	mm	2 740	2 740
I	Overall length (W/bucket)	mm	3 490	3 490
J	Angle of departure	°	25	25
K	Overall height	mm	1 980	1 980
L	Bucket width	mm	1 524	1 676
M	Over tire width (L/bucket)	mm	1 520	1 600
O	Turning radius rear	mm	1 650	1 650
P	Turning radius front L/bucket	mm	1 010	1 010
Q	Turning radius front W/bucket	mm	2 090	2 090

Pallet forks	Overall height	Overall width	Overall length	Adjustable tine spacing		Pallet fork rating	Overall weight
				mm	mm		
MC60C	mm	mm	mm	mm	mm	kg	kg
MC70C	984	1 194	1 313	229	1 143	2 722	206
	984	1 194	1 466	229	1 143	2 722	218

Data according to bucket type	Bucket	Width		Length	Height	Weight	Heaped cap
		mm	mm				
MC60C MC70C	General Purpose Bucket	1 372	800	521	136	0.33	
	General Purpose Bucket	1 524	800	521	146	0.36	
	General Purpose Bucket	1 676	800	521	200	0.39	
	Landscape Bucket	1 372	953	521	148	0.4	
	Landscape Bucket	1 524	953	521	160	0.45	
	Landscape Bucket	1 676	953	521	217	0.49	
	Multi Purpose Bucket	1 524	953	701	203	0.35	
Multi Purpose Bucket	1 676	953	701	259	0.45		

VOLVO C-SERIES SKID STEER LOADERS IN DETAIL.



	Units	MC95C	MC115C
Engine			
Model		404D-22T	TC-55
Cylinders		4	4
Fuel type		Diesel	Diesel
Displacement	cm ³	2 200	4 399
Aspiration		Turbo	Turbo
Cooling system		Liquid	Water
Horsepower			
SAE gross power	kW / hp	44.7 / 59.9	55 / 74
SAE net power	kW / hp	43.9 / 58.9	54.4 / 72.6
@ engine speed	@ rpm	2 800	2 400
Max. gross torque	Nm	189	327
@ engine speed	@ rpm	1 200	1 800
Electrical system			
Battery	V - Ah	12 - 101	12 - 109
Alternator	Ah	85	95
Starter	kW	2	2
Drivetrain			
Tires		10x16.5 - 8 PR Wide	12x16.5 - 10 PR
Hydraulics system-loader			
Std hydraulic pump output flow	lpm	70	87
High flow pump output	lpm	100	135
Engine speed	@ rpm	2 800	2 200
System pressure	bar	230	230
Service capacities			
Cooling system	l	15	15.5
Engine crankcase with filter, change	l	10.6	15
Fuel tank	l	98	103
Hydraulic system - total capacity	l	43.5	60
Hydraulic reservoir capacity	l	26	26
Performance			
Lift arm path		Vertical	Vertical
Rated operating capacity (SAE)	kg	862	1 179
Tipping capacity (SAE)	kg	1 723	2 471
Operating weight (SAE)	kg	3 127	3 705
Breakout force, lift	kg	1 570	2 669
Breakout force, curl	kg	2 140	2 585
Maximum travel speed			
Single speed	km/h	12	10.9
Two speed	km/h	9 / 18.5	10.9 / 20
Cycle time			
Raise (lifting)	s	4.3	5.1
Lower (power down)	s	2.7	3.5
Curl	s	1.6	1.4
Dump	s	2	1.8

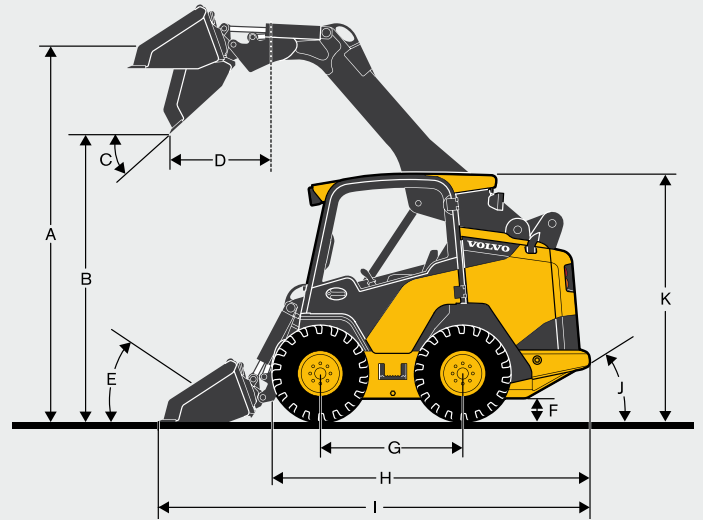
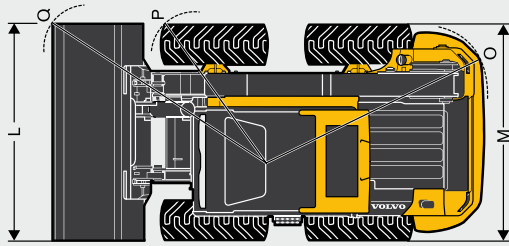

		Units	MC95C	MC115C
A	Height to hinge pin	mm	3 000	3 175
B	Dump height	mm	2 260	2 460
C	Dump angle	°	42	42
D	Dump reach	mm	860	870
E	Roll back angle	°	30	30
F	Ground clearance	mm	210	238
G	Wheelbase	mm	1 070	1 242
H	Overall length (L/bucket)	mm	2 780	2 940
I	Overall length (W/bucket)	mm	3 530	3 690
J	Angle of departure	°	25	28.7
K	Overall height	mm	1 980	2 090
L	Bucket width	mm	1 680	1 829
M	Over tire width (L/bucket)	mm	1 600	1 820
O	Turning radius rear	mm	1 650	1 760
P	Turning radius front L/bucket	mm	1 140	1 010
Q	Turning radius front W/bucket	mm	2 090	2 200

Pallet forks	Overall height	Overall width	Overall length	Adjustable tine spacing		Pallet fork rating	Overall weight
				mm	mm		
MC95C	mm	mm	mm	mm	mm	kg	kg
MC115C	984	1 194	1 313	229	1 143	2 722	206
	984	1 194	1 466	229	1 143	2 722	218

Data according to bucket type	Bucket	Width mm	Length mm	Height mm	Weight kg	Heaped cap m ³
	General Purpose Bucket	1 676	800	521	200	0.39
	General Purpose Bucket	1 829	800	521	215	0.43
	General Purpose Bucket	1 981	800	521	246	0.47
	General Purpose Bucket	2 134	800	521	261	0.5
	Landscape Bucket	1 676	953	521	217	0.49
	Landscape Bucket	1 829	953	521	232	0.54
	Landscape Bucket	1 981	953	521	264	0.58
	Landscape Bucket	2 134	953	521	279	0.63
	Multi Purpose Bucket	1 676	953	701	259	0.45
	Multi Purpose Bucket	1 829	953	701	352	0.57
	Multi Purpose Bucket	1 981	953	701	382	0.61
	Multi Purpose Bucket	2 134	953	701	401	0.66

EQUIPMENT.

STANDARD EQUIPMENT

	MC60C	MC70C	MC95C	MC115C
Engine				
4-cylinder, liquid-cooled, 8-valve, indirect-injection diesel engine	•	•	•	
4-cylinder, liquid-cooled, 16-valve, direct-injection diesel engine				•
Meet US EPA-Tier 4i, EU St3A	•	•	•	•
Self-cleaning, dual-element, air cleaner	•	•	•	•
12-Volt heavy-duty starter	•	•	•	•
Alternator with internal regulator	•	•	•	•
Quick cycle engine preheat	•	•	•	•
Engine oil remote drain hose	•	•	•	•
High-capacity radiator	•	•	•	•
Top mounted, tilt-up hydraulic oil cooler		•	•	•
Grid heater	•	•	•	•
Lift arm path				
Radial	•	•		
Vertical			•	•
Electrical				
Heavy-duty, maintenance-free battery – 760CCA		•	•	
Heavy-duty, maintenance-free battery – 1000CCA	•			•
Engine start/stop key switch	•	•	•	•
Fuel gauge	•	•	•	•
Electronic hand throttle	•	•	•	•
Coolant temperature gauge	•	•	•	•
Hourmeter	•	•	•	•
Charge pressure low	•	•	•	•
Engine oil low	•	•	•	•
Voltage low	•	•	•	•
Air flow restricted	•	•	•	•
Seat belt warning with 2-speed engaged		•	•	•
Warning lights	•	•	•	•
Warning lights flash	•	•	•	•
Hydraulic oil temperture high	•	•	•	•
Engine temperature high	•	•	•	•
Fuel low	•	•	•	•
Master electrical shut-off switch	•	•	•	•
In-cab fuse panel accessible without tools	•	•	•	•
2 front and 2 rear 50-Watt work lights (if AC)		•	•	•
2 front and 1 rear 50-Watt work lights (if no AC)	•	•	•	•
Transmission				
2 servo-assisted variable displacement piston pumps mounted in tandem	•	•	•	•
2 fixed displacement high torque motors	•	•	•	•
Hydraulics				
Lift-arm mounted auxiliary hydraulics	•	•	•	•
ISO hand pilot controls	•	•	•	•
Low flow case drain return line	•	•	•	•
5 micron filter for charge pressure	•	•	•	•

	MC60C	MC70C	MC95C	MC115C
10 micron filter for loader hydraulic return	•	•	•	•
Float function	•	•	•	•
Creep control	•	•	•	•
Safety				
Hydraulic park brake	•	•	•	•
Tilting cab	•	•	•	•
Emergency boom lower valve	•	•	•	•
Lift-arm support strut	•	•	•	•
Full audible and visual warning systems	•	•	•	•
Restraint activated safety system	•	•	•	•
Electric lift and tilt hydraulic lockouts	•	•	•	•
Back-up alarm	•	•	•	•
Emergency exit through front windshield	•	•	•	•
Cab				
Isolation mounted canopy with low left-hand side door and laminated right hand glass	•	•	•	•
ROPS and FOPS	•	•	•	•
Top window	•	•	•	•
Mechanical suspension seat	•	•	•	•
Pod storage area	•	•	•	•
Cup holder	•	•	•	•
12-Volt power accessory outlet	•	•	•	•
Rear view mirror	•	•	•	•
Interior light	•	•	•	•
2" retractable seat belt	•	•	•	•
Operator seat bar	•	•	•	•
Other				
Lockable rear service door and engine cover	•	•	•	•
Lockable fuel cap	•	•	•	•
Mechanical attachment bracket	•	•	•	•

OPTIONAL EQUIPMENT

	MC60C	MC70C	MC95C	MC115C
Cab				
Heated fully glazed sealed and pressurized cab enclosure, washer/wiper and sliding left hand window	•	•	•	•
Air conditioned/heated fully glazed sealed and pressurized cab enclosure, washer/wiper and sliding left hand window		•	•	•
Air suspension seat, heated, vinyl, with adjustable control pods	•	•	•	•
Air suspension seat, heated, cloth, with adjustable control pods (not available on canopy)	•	•	•	•
3" retractable seat belt	•	•	•	•
2" 3 point retractable seat belt	•	•	•	•
3" 3 point retractable seat belt	•	•	•	•
Radio with Auxiliary input	•	•	•	•
Keyless start	•	•	•	•
Immobilizer key (not available with Keyless start)	•	•	•	•
Impact protection laminated glass (for canopy)	•	•	•	•

OPTIONAL EQUIPMENT

	MC60C	MC70C	MC95C	MC115C
Impact protection Lexan screen	•	•	•	•
Right hand mesh on canopy (replaces standard laminated glass)	•	•	•	•
Canopy full door with mesh	•	•	•	•
Performance package				
Comfort pack including: - Foot throttle - Parallel lift	•	•	•	•
Deluxe pack including: - Foot throttle - Parallel lift - Hydraulic attachment bracket - Boom Suspension System (Not on MC60C)	•	•	•	•
Controls				
ISO hand pilot 7-way controls	•	•	•	•
Engine				
Spark arrestor muffler	•	•	•	•
Engine block heater 110V	•	•	•	•
Engine block heater 240V	•	•	•	•
Wide core radiator	•	•	•	•
Hydraulics				
High flow auxiliary hydraulic		•	•	•
Left hand mounted auxiliary couplers	•	•	•	•
Low flow case drain return line	S	S	S	•
Electrical				
Rotating beacon light	•	•	•	•
Road light kit	•	•	•	•
Anti-theft keypad	•	•	•	•
Tires				
Standard duty lug tires	•	•	•	•
Heavy-duty lug tires	•	•	•	•
Heavy-duty wide flotation lug tires	•	•	•	•
Non-pneumatic solid tires	•	•	•	•
Non-pneumatic cushioned solid tires	•	•	•	•
Other				
2-speed travel		•	•	•
Twine cutter	•	•	•	•
Hardide pivot pins (arm to coupler)	•	•	•	•
Travel lock kit	•	•	•	•
Segment protection packages				
Equip your Skid Steer Loader with special application packages, including: - FOPS level 2 roof guard - Front screen guard - Heavy duty rear bar - Lexan screen - etc				
Contact your local dealer for more info				

S = Standard

SELECTION OF VOLVO OPTIONAL EQUIPMENT

Heated cab with air conditioning for year-round comfort



Choice of Tire to best suit your job



High flow auxiliary hydraulics



2-speed option helps you get the job done faster



Volvo hydraulic attachment bracket allows the operator to change attachment from the seat (Included in the Deluxe package)



VOLVO CONSTRUCTION EQUIPMENT

Volvo Construction Equipment is different. Our machines are designed, built and supported in a different way. That difference comes from an engineering heritage of over 180 years. A heritage of thinking first about the people who actually use the machines. About how to help them be safer, more comfortable, more productive. About the environment we all share. The result of that thinking is a growing range of machines and a global support network dedicated to helping you do more. People around the world are proud to use Volvo.

Not all products are available in all markets. Under our policy of continuous improvement, we reserve the right to change specifications and design without prior notice. The illustrations do not necessarily show the standard version of the machine.

VOLVO

Volvo Construction Equipment
www.volvoce.com

Ref. No 20033643-C
2013.10
Volvo, Global Marketing

English-21
SSL